

NOTE: THESE DRAWINGS ARE ISSUED FOR GENERAL INFORMATION ONLY AND ARE NOT INTENDED FOR MODIFICATION. FOR FURTHER INFORMATION PLEASE CONSULT OUR SALES OR ENGINEERING DEPARTMENTS.

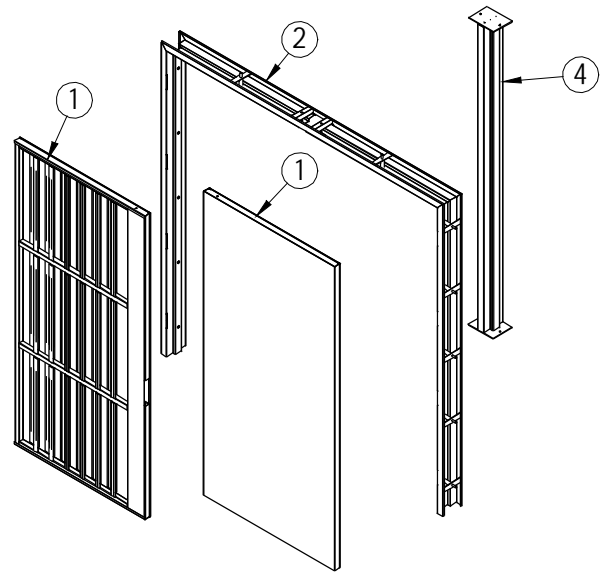

EXPLODED VIEW

- LEGEND:**
1. REINFORCED TORNADO RESISTANT STEEL DOORS.
 2. TORNADO RESISTANT STEEL FRAME .
 3. HEAVY DUTY TUBE & SCREW WALL ANCHORS.
 4. REMOVABLE REINFORCED MULLION.
- NOTES:**
1. SUPER HEAVY HINGES SHIPPED LOOSE.
 2. 3 PT. LOCK OR EXIT DEVICE, FACTORY INSTALLED.

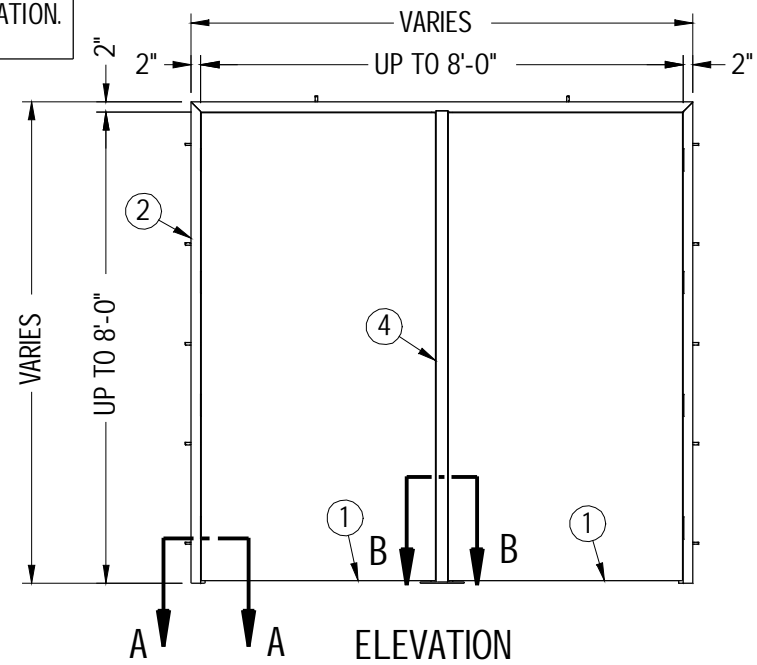

ELEVATION

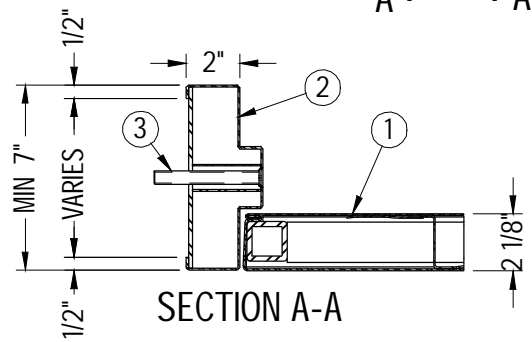

SECTION A-A

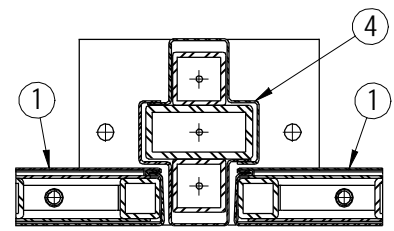

SECTION B-B

TORNADO RESISTANT DOUBLE DOOR & FRAME UNIT - OVER 6' X 7'