

NOTE: THESE DRAWINGS ARE ISSUED FOR GENERAL INFORMATION ONLY AND ARE NOT INTENDED FOR MODIFICATION. FOR FURTHER INFORMATION PLEASE CONSULT OUR SALES OR ENGINEERING DEPARTMENTS.

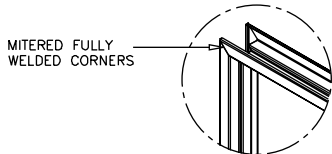

MITERED FULLY WELDED CORNERS

CORNER DETAIL 'B'

LEGEND

1. PRESSED STEEL FULLY WELDED BULLET RESISTANT FRAME.
2. HOLLOW METAL BULLET RESISTANT DOOR.
3. VOIDS FILLED WITH INSULATION.
4. ARMOUR SHIELD PLATE TO UL752. ARMOUR SHIELD MAY VARY IN THICKNESS AS REQUIRED TO ACHIEVE PERFORMANCE RATING.
5. HORIZONTAL STEEL STIFFENERS.



NOTE: - THE DOORS ARE SUPPLIED WITH A FLAT 2" WIDE OVERLAPPING ASTRAGAL LINED WITH ARMOUR SHIELD.

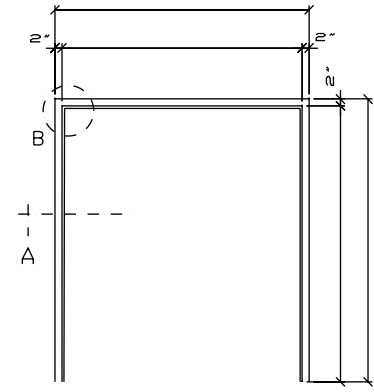

ELEVATION

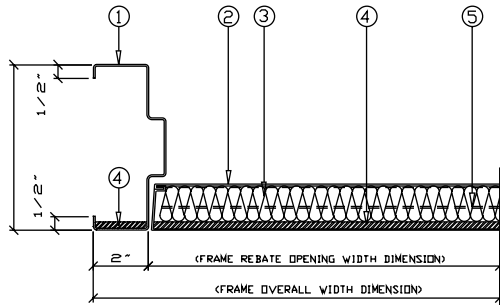

SECTION 'A'

SIDELITE, BORROWED LITE, AND DOORS WITH VISION LITES ARE AVAILABLE. SEE VISION LITE DETAIL DRAWINGS ON WEBSITE FOR LEVELS 1 THROUGH 4. FOR OTHER OPTIONS, PLEASE CONSULT FACTORY.

PRODUCT STANDARDS

ALL PRODUCTS ARE TESTED AND CERTIFIED IN ACCORDANCE WITH UL 752. ALL DOORS AND FRAMES SHALL BE SUPPLIED IN GALV. MATERIAL WITH FULL FACTORY PRIME PAINT FINISH. ALL SHALL BE TEMPLATED, REINFORCED, AND DRILLED & TAPPED FOR MORTISED HARDWARE. TEMPLATING FOR SURFACE APPLIED HARDWARE SHALL BE BY OTHERS. ACCESS HOLES THROUGH THE ARMOUR SHIELD SHALL BE PROVIDED IN THE FACTORY FOR SURFACE APPLIED HARDWARE ON LEVELS 4 THROUGH 8 ONLY. FRAMES SHALL BE PROVIDED MITERED AND FULLY WELDED, INCLUDING BUMPERS, WALL ANCHORS, FLOOR CLIPS, AND SHALL BE SHIPPED WITH TEMPORARY SPREADERS FOR SUPPORT DURING SHIPPING. THE DOORS SHALL HAVE VISIBLE MECHANICALLY INTERLOCKING WELDED EDGE SEAMS. THE DOOR UNDERCUT IS 3/4", UNLESS HARDWARE TEMPLATING DICTATES OTHERWISE OR SPECIFICALLY NOTED BY ARCHITECT OR CUSTOMER.

PRODUCT OPTIONS

- TACK & FILLED "SEAMLESS EDGE SEAMS
- FLUSH CLOSED TOP CAP
- FLUSH CLOSED BOTTOM CAP

JOB NO:

SHEET:

OF: