

NOTE: THESE DRAWINGS ARE ISSUED FOR GENERAL INFORMATION ONLY AND ARE NOT INTENDED FOR MODIFICATION. FOR FURTHER INFORMATION PLEASE CONSULT OUR SALES OR ENGINEERING DEPARTMENTS.

LEGEND

1. FULLY WELDED BLAST RESISTANT STEEL FRAME
2. REINFORCED BLAST RESISTANT STEEL DOOR
3. PROPRIETARY BLAST RESISTANT DOOR CORE
4. SEMI-RIGID FIBERGLASS INSULATION TO FILL ALL VOIDS
5. REINFORCE FOR MORTISE HINGES (SEE CHART)
6. REINFORCE FOR SURFACE APPLIED CLOSER.
7. INVERTED CHANNELS TO CLOSE TOP & BOTTOM OF DOOR.
8. REINFORCE FOR CONCEALED VERTICAL ROD EXIT DEVICE (SEE CHART) AND PROVIDE ACCESS PANELS AS REQUIRED FOR LUBRICATION & MAINTENANCE
9. QUANTITY OF HORIZONTAL AND VERTICAL STRUCTURAL MEMBERS VARIES IN ACCORDANCE WITH PRESSURE LEVEL AND SIZE.
11. REINFORCE FRAME FOR CONCEALED VERTICAL ROD EXIT DEVICE STRIKE

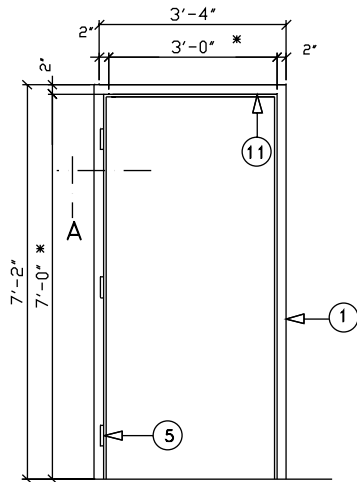

FRAME ELEVATION

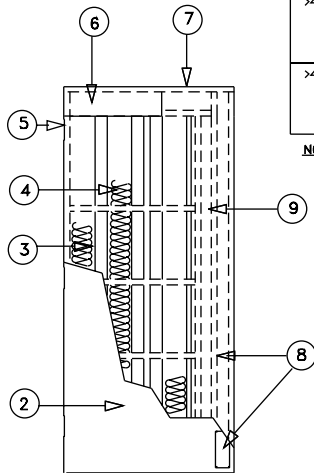

DOOR ELEVATION

OPENING WIDTH (INCHES)	BLAST RESISTANT DOOR HARDWARE CHART				
	OPENING HEIGHT (INCHES)	UP TO 84	>84-90	>90-108	>108-210
36	WEIGHT (LBS) HINGES LATCHES	QTY.3-SUPER HD CONC'D-VERT.ROD 5/8" DIA. RODS	CONSULT FACTORY	CONSULT FACTORY	CONSULT FACTORY
>36-42	WEIGHT (LBS) HINGES LATCHES	QTY.3-SUPER HD CONC'D-VERT.ROD 5/8" DIA. RODS	CONSULT FACTORY	CONSULT FACTORY	CONSULT FACTORY
>42-48	WEIGHT (LBS) HINGES LATCHES	QTY.3-SUPER HD CONC'D-VERT.ROD 5/8" DIA. RODS	CONSULT FACTORY	CONSULT FACTORY	CONSULT FACTORY
>48-55	WEIGHT (LBS) HINGES LATCHES	CONSULT FACTORY	CONSULT FACTORY	CONSULT FACTORY	CONSULT FACTORY

NOTE: CONCEALED VERTICAL ROD EXIT DEVICE SUPPLIED AS EXIT ONLY, THUMB PIECE TRIM, OR LEVER HANDLE TRIM FUNCTIONS ONLY.

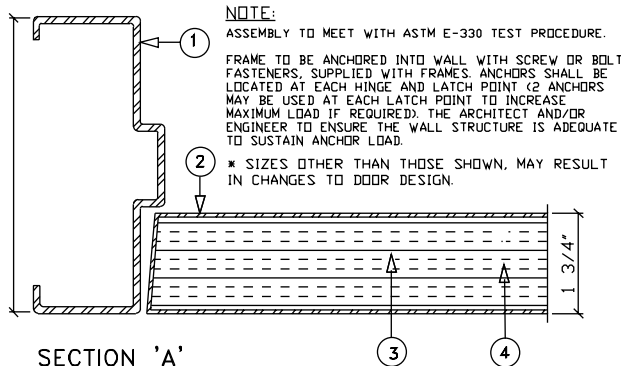

SECTION 'A'

NOTE:
ASSEMBLY TO MEET WITH ASTM E-330 TEST PROCEDURE.
FRAME TO BE ANCHORED INTO WALL WITH SCREW OR BOLT FASTENERS, SUPPLIED WITH FRAMES. ANCHORS SHALL BE LOCATED AT EACH HINGE AND LATCH POINT (2 ANCHORS MAY BE USED AT EACH LATCH POINT TO INCREASE MAXIMUM LOAD IF REQUIRED). THE ARCHITECT AND/OR ENGINEER TO ENSURE THE WALL STRUCTURE IS ADEQUATE TO SUSTAIN ANCHOR LOAD.
* SIZES OTHER THAN THOSE SHOWN, MAY RESULT IN CHANGES TO DOOR DESIGN.