

LEGEND:

- 1. ACOUSTIC STEEL FRAME.
- 2. ABSORPTION CHAMBER.
- 3. CLEAR ACOUSTIC LAMINATED GLASS BY AMBICO.
- 4. CLEAR ACOUSTIC LAMINATED GLASS BY AMBICO.
- 5. REMOVABLE BEADS.
- 6. PURGING PORTS (2) PLACES.

NOTE: MINIMUM JAMB DEPTH IS 1 3/4".

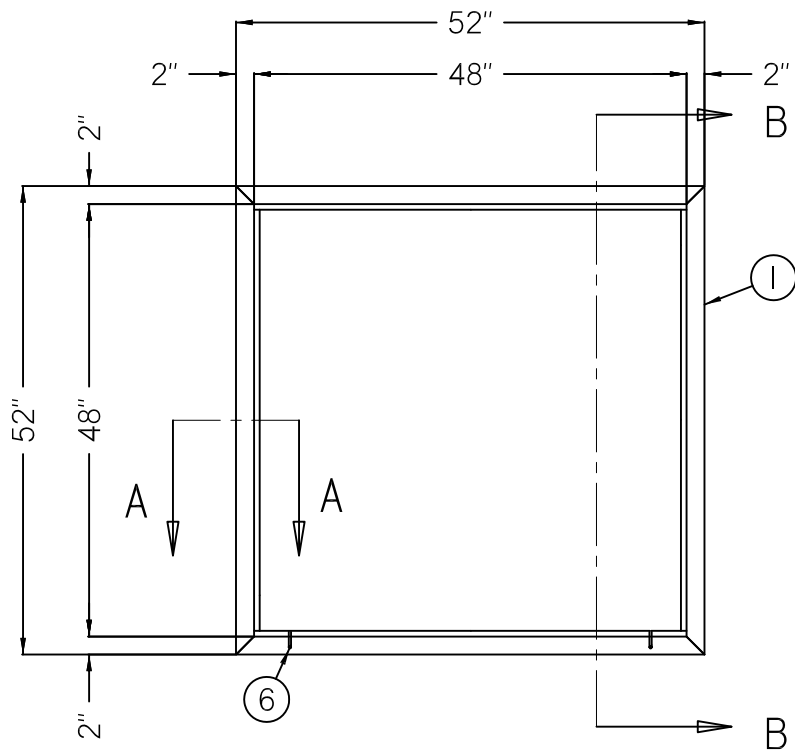

ELEVATION

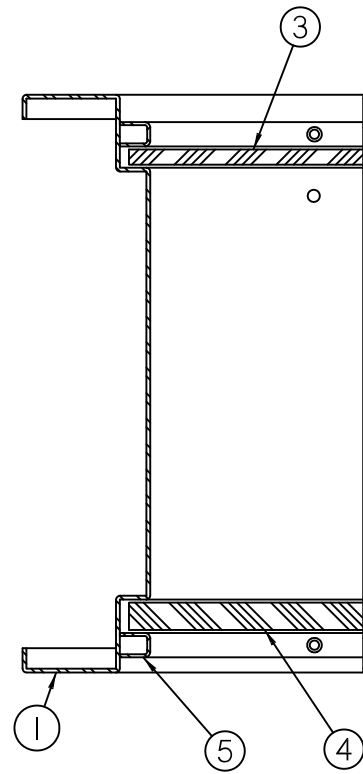

SECTION A-A

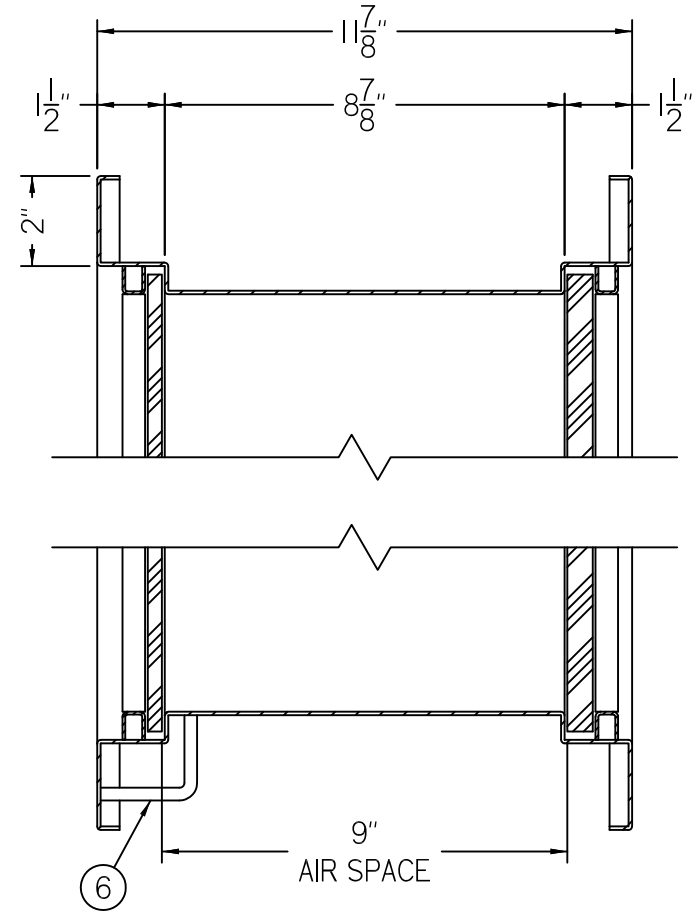

SECTION B-B

NOTE: ACOUSTIC STEEL BORROWED LITES CAN BE ENLARGED IN SIZE - CONSULT FACTORY

ACOUSTIC STEEL BORROWED LITE UNIT STC - 56

JOB NO:

SHEET:

OF: